

# Titan Manufacturing

## Trailer Handbook

### Operator's Manual for Tri Axle, Quad Axle and Five Axle floats



Tri Axle Certification #285345A

Quad Axle Certification #38193

Five Axle Certification #41077

Congratulations on purchasing your new Titan Trailer. Please take the time to read this manual carefully to ensure you obtain optimum results from your new trailer. This manual will cover all deck widening trailers including Tri Axle, Quad Axle and Five Axle Trailers.

## CONTENTS

• FOREWORD	3
• 1.0 SAFETY PRECAUTIONS	4
○ 1.1 GENERAL SAFETY INFORMATION	5
○ 1.2 SAFETY PRECAUTIONS	6
○ 1.3 LOADING AND UNLOADING	7
• 2.0 MACHINE FAMILIARIZATION AND OPERATION	8
○ 2.1 FAMILIARIZATION	9
○ 2.2 GENERAL TRAILER PARTS	9
○ 2.3 HOOKUP AND DETACHEMENT OF TRAILER	10
○ 2.4 REVERSING TRAILER	11
○ 2.5 RAMP OPERATION	12
○ 2.6 DECK WIDENING	13
○ 2.7 LOAD RESTRAINT	14
○ 2.8 LANDING LEG OPERATION	15
• 3.0 MAINTENANCE	16
○ 3.1 GENERAL SAFETY & PRECAUTIONS	17
○ 3.2 DAILY INSPECTIONS	18
○ 3.3 5,000km/WEEKLY INSPECTION	19
○ 3.4 20,000km/MONTHLY INSPECTION	20
• 4.0 SPECIFICATIONS	21
○ 4.1 GENERAL DIMENSIONS	22

## FOREWORD

### AVOID INJURY

**Read, understand and follow all safety precautions and procedures found in this manual before attempting operation, inspection or maintenance of this equipment. Manufacturer cannot anticipate every possible circumstance that might involve a potential hazard. The warnings in this publication and on the product are therefore not all inclusive. If a tool, procedure, work method or operation technique not specifically recommended by the manufacturer is used, you must satisfy yourself that it is safe for you and others. You should also ensure that the product will not be damaged or made unsafe by the operation, lubrication, maintenance and/or repair procedures you choose.**

---

### GENERAL

- This manual contains procedures to aid the operator gain peak performance through effective, economical operation and the maintenance of the equipment.
- Before using the equipment, operators must thoroughly read and understand all Safety, Operation and Maintenance instructions found in this manual. Failure to follow the instructions given in this manual may lead to serious injury to persons or equipment failure.
- Operators and persons working with this equipment should continually study this manual until proper Safety, Operation and Maintenance procedures are completely understood.
- This manual describes the basic operating techniques. Skill is gained as the operator utilizes these techniques and perfects them with the actual equipment
- Some pictures may be different from your equipment, as technical improvement is continuous, manuals are periodically updated to reflect these changes.
- This manual may not contain optional equipment. Please contact an authorized Manufacturer for any optional equipment required.
- The contents of this manual and operation of the equipment are based on the use of genuine manufacturer sourced parts. Use of non-genuine replacement or modified parts is not recommended.
- Materials and specifications are subject to change without notice

### NOTICE

- Owing to the policy of continual improvement, changes may be made by the manufacturer to any of its products without any obligation on the part by the manufacturer.
-

# **1. SAFETY PRECAUTIONS**

## 1.1 GENERAL SAFETY INFORMATION

---

### AVOID INJURY OR DEATH

Do not operate or perform any maintenance on this trailer until all instructions found in this manual have been thoroughly read and understood.

Improper operation or maintenance of this equipment may cause accidents and could result in serious injury or death.

Always keep this manual with the trailer for further reference.

If manual is lost or damaged, call manufacturer for replacement or log onto Titan's website to download another copy ([www.titanmanufacturing.com.au](http://www.titanmanufacturing.com.au))

---

1. Most accidents, which occur during operation, are due to neglect of precautionary measures and safety rules. Sufficient care should be taken to avoid these accidents. Lubrication and maintenance services can be very dangerous and may cause injury. Therefore all precautionary measures, DANGERS, WARNINGS, CAUTIONS and IMPORTANT contained in this manual and on the trailer should be read and understood by all personnel before starting any work with or on the trailer.
  2. Operation, inspection, and maintenance should be carefully carried out, and safety must be given the first priority. Safety messages are indicated using the following safety alert symbols and signal words. The safety information contained in this manual is intended only to supplement safety codes, insurance requirements, local laws, rules and regulations.
  3. *Messages of safety appear in this manual and are identified by the words "DANGER", "WARNING", "CAUTION" and "IMPORTANT".*
  4. While using this equipment, be sure to work with great care to avoid damage to the trailer, and accidents from occurring.
-

## 1.2 SAFETY PRECAUTIONS

---

### AVOID INJURY OR DEATH

The proper and safe lubrication and maintenance for this trailer as recommended by the manufacturer, is outlined in the operator's manual for this trailer.

**Improper performance of lubrication or maintenance procedures are dangerous and could result in injury or death. Read and understand this operator's manual before performing any lubrication or maintenance.**

---

The serviceman or mechanic may be unfamiliar with many of the systems on this equipment. This makes it important to use caution when performing service work. Knowledge of the systems and components is important before removal or disassembly of any component.

Because of the size of some components on this equipment, the serviceman or mechanic should use correct lifting procedures and if unsure of their capabilities of lifting, should consider a two person or assisted lift.

The following is a list of basic precautions that must always be observed.

1. Read and understand this manual before operating, maintaining or repairing this equipment.
  2. Always wear protective glasses and protective shoes whenever working on this equipment. In particular, wear protective glasses when using hammers, punches or drifts on any part of this equipment. Use safety gloves, hood/goggles, apron and the protective clothing appropriate to the welding job being performed. Do not wear loose fitting or torn clothing. Remove all rings from fingers, loose jewelry, confine long hair and loose clothing before working on this equipment.
  3. If possible, make all repairs with the equipment parked on a level, hard surface. Block the wheels so it cannot roll while working on or under the trailer and apply maxi brakes.
  4. Do not work on any trailer that is supported only by lift, jacks or a hoist. Always use blocks or jack stands, capable of safely supporting the weight of the trailer, before performing any disassembly.
  5. Relieve all pressures in hydraulic lines before disconnecting. Always make sure raised components are blocked correctly to ensure they cannot fall when lines are disconnected eg: the ramps or hydraulic suspension.
  6. Always use steps carefully to mount and dismount the trailer. Clean any mud, grease, oil or debris from steps. Always face the trailer when using steps.
  7. Avoid back injury. Use a hoist when lifting components which weigh 20kg (45lb) or more. Make sure all chains, hooks, slings, etc. are in good condition and are the correct capacity. Be sure hooks are positioned correctly. Lifting eyes are not to be side loaded during a lifting operation.
  8. Repairs which require welding should be performed only with the benefit of the appropriate reference information and by personnel adequately trained and knowledgeable in welding procedures. Determine the type of metal being welded and select correct welding procedure to provide a weld metal strength at least equivalent of that of the parent metal.
-

## 1.3 LOADING AND UNLOADING

---

### DANGER

**Loading machinery onto the trailer can be dangerous if not done correctly. Take great care whenever moving equipment onto the trailer. Read and fully understand the operator's manual before commencing any loading or unloading of equipment.**

---

1. When loading/unloading machinery do not use machine buckets/attachments to exert excessive force to deck or ramps of the trailer.
  2. Remove all mud, oils and grease from the ramps surface to prevent the machine from skidding or sliding off the trailer.
  3. Do not change the travelling direction of machinery on the ramp or trailer deck as this may cause severe damage to the trailer. Instead, back the machine down to the ground, reposition, and try again.
  4. Always use low travel speed for loading or unloading of the trailer.
  5. Always use correct tie down procedures to restrain machinery/equipment to the deck of the trailer.
  6. Always ensure you do not overload the trailer. The total load capacity that can be carried on the trailer can be found on the VIN plates.
-

## **2. MACHINE FAMILIARIZATION AND OPERATION**

## 2.1 FAMILIARIZATION

### IMPORTANT

Read and fully understand this operator's manual before commencing any work with or to the trailer. Failure to follow this instruction manual could result in serious injury or damage to trailer.

All operators, service mechanics and personnel responsible for operation, inspection and maintenance of the trailer should become thoroughly familiar with the controls and components and their functions before working with or on this equipment. Study the information in this section to become familiar with the controls and components of this equipment and how to use them.

## 2.2 GENERAL TRAILER PARTS

The diagram below illustrates the major components of the **quad axle trailer**. These will be the same on both *tri axle* and *five axle* trailers although the number of axles and suspension components will vary. Specific information on important components will be listed further in the operator's manual.

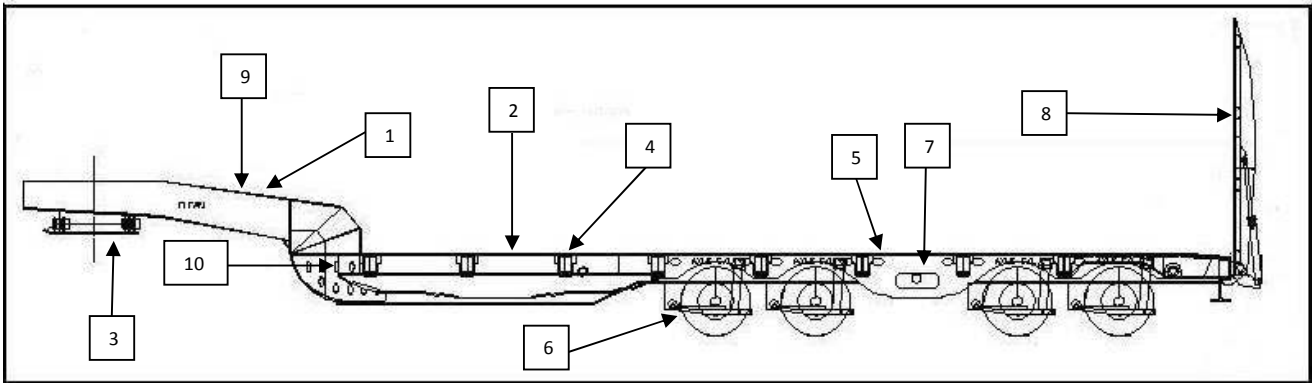

Item Number	Description
1	Drawbar
2	Trailer Deck
3	Rocker Box
4	Deck Widening Slides
5	Tie Down Points
6	Wheels, Tyres and Suspension setup
7	Toolbox
8	Ramps
9	Toolbox
10	Toolbox (Both Sides)

## 2.3 HOOKUP AND DETACHMENT OF TRAILER

### CAUTION

Trailer hookup and detachment can be a dangerous exercise if not carried out in a proper manner and can lead to severe injury or death

Before connecting the trailer to the truck follow these simple steps to ensure maximum safety.

- Clear area in front of trailer for ease of connection.
- Block wheels of trailer and ensure trailer brakes are in the 'ON' position in your truck.
- Check that the trailer is at the correct height for your truck. If it is not, adjust the landing legs up or down until the trailer is at the correct height.
- Check that the truck turntable is in the open position
- Ensure the hoses on the truck are clear of the turntable so they are not jammed between the truck turntable and the trailer.
- Back the truck turntable under the trailer rocker box until the safety on the turntable locks the trailer on.
- Connect hydraulic oil lines (if trailer is powered by truck PTO); (T) Return to tank (P) Pressure line.
- Connect air lines to allow air to fill the trailer air tanks.
- Connect electric lighting 7 pin plug for trailer lights.
- Raise landing leg.

Before disconnecting the trailer from the truck follow these simple steps to ensure maximum safety.

- Turn trailer brakes to 'ON' position in your truck.
- Lower landing legs and block trailer wheels.
- Disconnect electric lighting plug, air leads and if applicable, oil lines.
- Open turntable on truck.
- Slowly proceed forward until truck is clear of trailer.

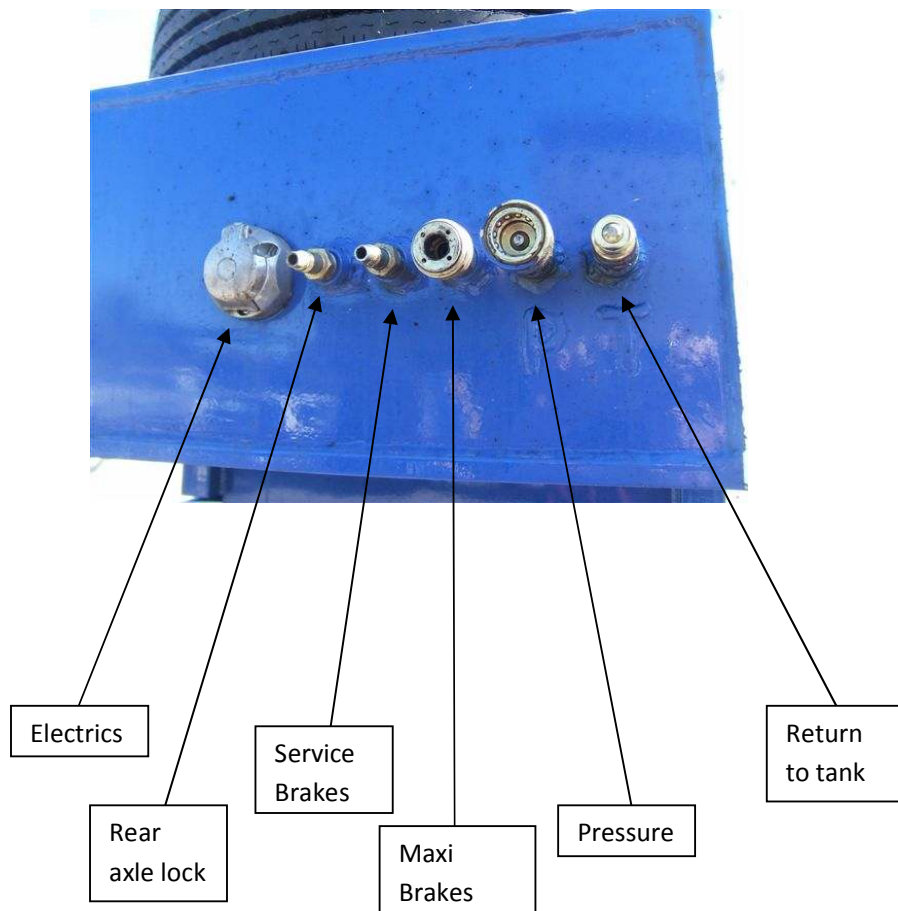

## **2.4 REVERSING TRAILER (WITH REAR STEERABLE AXLES)**

---

### **IMPORTANT**

For trailers fitted with rear axle steering to assist towing in tight areas, the rear steer axles must be locked before attempting to reverse. Failure to lock the rear axles will result in severe damage to axles and rear suspension. The rear axles are locked by an air operated booster valve. An air operated switch must be installed in the truck which will allow the locking of the rear axles. Once the switch is activated the operator must continue to drive in a straight line for a further 20-30 metres to ensure the wheels have straightened and locked in before attempting to back the trailer.

---

## 2.5 RAMP OPERATION

Before raising or lowering of the ramps, ensure the area behind the trailer is free of persons, other equipment, rocks, logs, gutters etc. Failure to lower ramps on a flat surface may cause the ramps to bend when a load is put on them. Remove the safety chains from the ramps and then move to the ramp controls, which in most cases are located with the deck widening controls at the rear of the trailer. Slowly lower one ramp until it is fully on the ground before proceeding to lower the other ramp. Once the machine is loaded ensure the ramps will not hit the machine in the fully upright position before beginning to raise the ramps. Once again, raise one ramp at a time to ensure you do not overload the hydraulic pump. Once the ramps are in the fully raised position, replace the safety chains to the correct position before proceeding to move the trailer. DO NOT tow the trailer without the ramp safety chains securely attached.

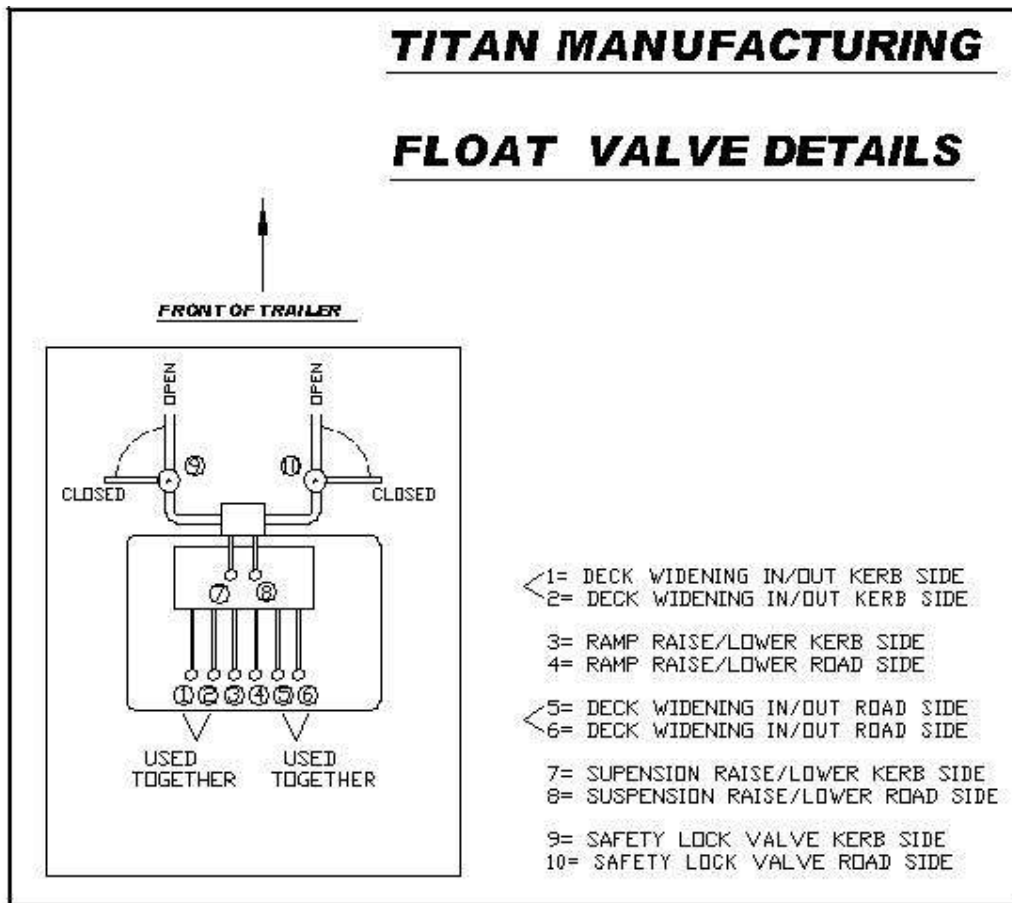

## 2.6 DECK WIDENING

---

### DANGER

**Widening of the deck can be dangerous. Do not allow anyone to stand or walk on the deck while it is opening or closing. Failure to follow this procedure could lead to death or serious injury.**

---

When using the deck-widening feature of your trailer you must ensure that the trailer is on flat, level ground. With the ramps in the raised position use the deck widening levers, located at the rear of the trailer with the ramp levers, and open one side at a time. Remember to only use one lever at a time and open the front of the trailer, then the rear, in increments of around 3 inches. Always operate the trailer with each side opened evenly to prevent damage to the trailer chassis. DO NOT try to open the front or the rear of the trailer fully at once or this will cause the trailer bed to jam and may cause damage to the trailer. Always remember to follow your State Regulations in relation to over-width vehicles. The manufacturer will not be held responsible for any fines incurred from operating an over-width or over-loaded trailer.

---



**DANGER: Do not allow anyone to stand or walk on the deck while it is opening or closing. Failure to follow this procedure could lead to death or serious injury.**

---

## 2.7 LOAD RESTRAINT

---

### CAUTION

**Carrying heavy loads can be dangerous and should be performed with great care. Always follow State Load Restraint Regulations. DO NOT under any circumstances carry a load that is not correctly secured.**

---

When restraining a load you should consider the following points to ensure the load is secure.

- Position the load correctly.
- Use suitable restraint equipment for the load you are carrying.
- Use good quality restraint equipment, in good condition.
- Check your load restraint immediately before leaving and during your trip.
- You are driving under different, more difficult conditions when you are carrying certain types of loads
- Unload safely.
- Failure to restrain a load correctly on a vehicle may result in legal action being taken against any persons involved.
- The manufacturer takes no responsibility for any fines incurred or any damage caused by / to the trailer resulting from incorrectly restrained loads.
- Without sufficient restraint to counteract driving maneuvers, the forces on an unrestrained load can cause the load to fall from the trailer or shift, causing loss of steering control.
- Use only the tie down points provided by the manufacturer.

The National Road Transport Reform (Mass and Loading) Regulations 1995 require that:

- A load on a vehicle/trailer must not be placed in a way that makes the vehicle unstable or unsafe.
  - A Load on a vehicle must be secured so that it is unlikely to fall or be dislodged from the vehicle/trailer.
  - An appropriate method must be used to restrain the load on a vehicle/trailer.
-

## 2.8 LANDING LEG OPERATION

Trailer landing legs are located at the front of the trailer deck and are used to hold the trailer up when not in use. Always ensure the landing legs are wound all the way up before driving with the trailer attached so as to not damage them by dragging them along the ground. Failure to do so may void your warranty.

### Manual Landing Legs

- Remove handle from holder on gooseneck.
- Wind handle in correct direction to make legs go up/down.
- Replace handle once finished.

The manual landing legs have two speeds. One for speed, and one that will enable it to be used to take the weight of the trailer. To change between these speeds simply pull or push the handle then continue winding.

### Hydraulic Landing Legs

- Use hydraulic levers found on side of gooseneck to raise or lower the landing legs.

The hydraulic landing legs will require grease to be applied on a daily basis to the feet on the end of the rams to ensure they do not jam or seize. Failure to grease on a daily basis may void your warranty.



## **3.0 MAINTENANCE**

### 3.1 GENERAL SAFETY & PRECAUTIONS

---

#### WARNING

Do not attempt inspection or maintenance procedures other than those specified in the manual. Carry out all maintenance on the trailer on flat level ground.

---

#### IMPORTANT

For major repairs, modifications and replacement parts please contact the manufacturer to ensure manufacturer's warranty is not void.

---

It is recommended that an inspection and maintenance schedule be developed and maintained with written records, on a regular basis to aid with any warranty claims. An example maintenance schedule is demonstrated below.

DATE	MAINTENANCE/WORK CARRIED OUT
4/9/2009	Greased trailer, checked wheel nuts, checked lights, checked torque on suspension bolts, checked torque on U-Bolts, checked brakes.
5/9/2009	Checked for loose nuts and bolts before operation, checked lights and tyres.
6/9/2009	Checked for loose nuts and bolts before operation, checked lights and tyres.

## 3.2 DAILY INSPECTION

### WARNING

Some maintenance procedures can be dangerous and cause injury. Take great care whenever working on this trailer. Read and fully understand the safety precautions in manual before completing any work on the trailer.

Before starting daily operation, walk around the trailer to check for any loose nuts and bolts, any hydraulic fluid leaks and the condition of the tyres. Check all lights are working and that there are no electrical shorts. Repair and clean as necessary.

1. Inspect condition of tyres and tyre pressure levels.
2. Check around and under the trailer for any hydraulic oil that may be leaking and repair as required.
3. Check ramp safety chains are fitted.
4. Check all lights and electrical system and repair as required.
5. Check that all nuts and bolts are secure. Replace or tighten bolts as required as it is not uncommon for nuts and bolts to lose tension through daily use.
6. Grease all points on trailer specified in images below.
7. Inspect hydraulic oil level if trailer is fitted with power-pack.

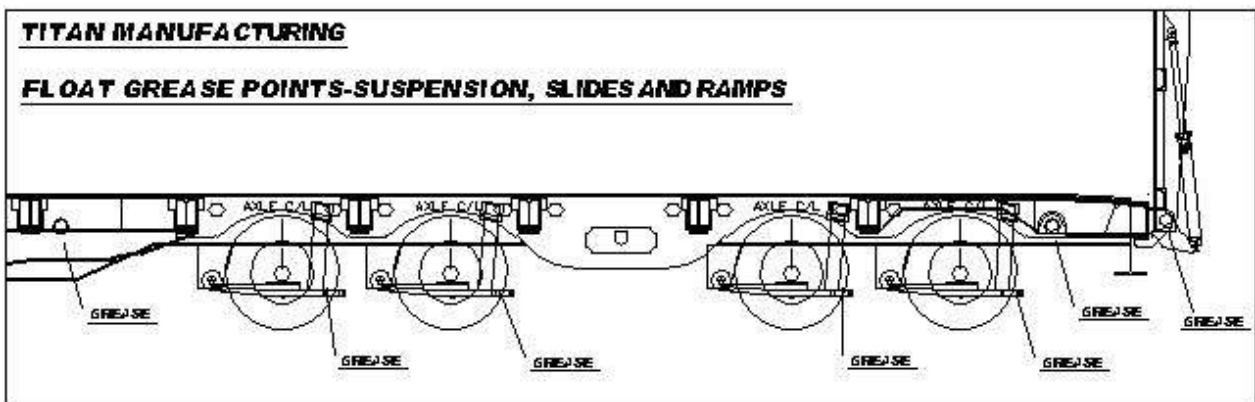
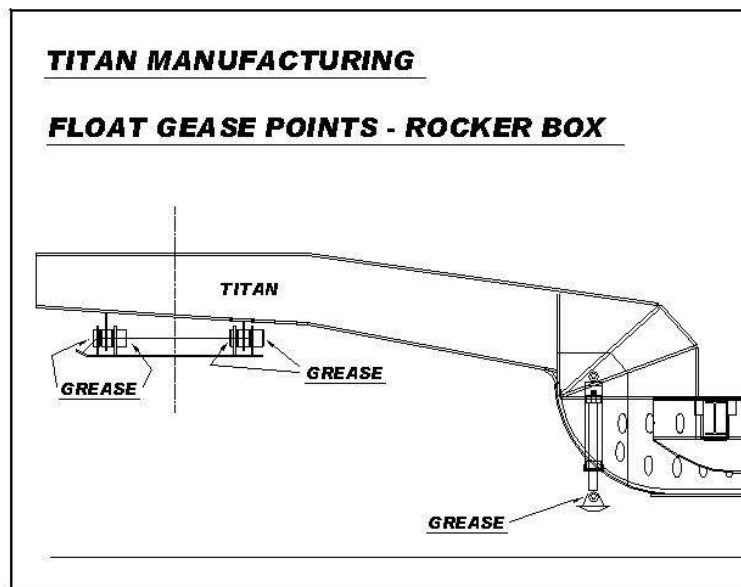



### **3.3 5000km/WEEKLY INSPECTION**

---

#### **WARNING**

**Some maintenance procedures can be dangerous and cause injury. Take great care whenever working on this trailer. Read and fully understand the safety precautions in manual before completing any work on the trailer.**

---

Every 5000km's you must perform a thorough inspection and service of the trailer. This includes all items required as part of the Daily Inspection in addition to a more thorough inspection of the trailers operating systems. This should be carried out by a qualified mechanic.

1. As per item 3.2 DAILY INSPECTIONS – all items.
  2. Inspect wheel nuts with a wheel brace and tighten accordingly.
  3. Check torque of suspension U-Bolts and tighten.
  4. Adjust brakes.
  5. Inspect all air lines for leaks and repair accordingly.
  6. Inspect all suspension components for any leaks or damage that may have occurred and repair accordingly.
  7. Thoroughly clean and inspect trailer for any cracks or damages.
- 

### **3.4 20,000km/MONTHLY INSPECTION**

---

Every 20,000km's you must remove the brake hubs and inspect the condition of the brake shoes and drums, check the condition of the wheel bearings and thoroughly clean and inspect the trailer. This service must be carried out by a qualified mechanic. Failure to have completed by a qualified mechanic may void manufacturer's warranty.

1. Remove wheels.
2. Remove brake drums.
3. Inspect condition of brake shoes. Check there is enough shoe left for a further 20,000km's. If worn out, replace.
4. Inspect condition of brake drums, look for any scoring, lips or cracks in the drum. If any damage is found replace the drum.
5. Inspect condition of wheel bearings, check for any marks in bearings or scoring in the bearing cup, re-pack bearings with fresh bearing grease then re-torque bearings to correct torque.
6. Re-assemble all components and ensure all nuts and bolts are tight.
7. Re-adjust brakes.

## **4.0 SPECIFICATIONS**

## 4.1 GENERAL DIMENSIONS

The measurements illustrated in this section are indicative general dimensions applicable to all Tri Axle, Quad Axle and Five Axle deck widening floats. These include items such as ramp lengths, heights when ramps upright and departure angles, deck heights, width when trailer is closed and width when trailer is in fully open position. Deck lengths and drawbar heights and lengths will not be included as each trailer may vary. Ramps shown in these drawings will be of standard single length and not bi-fold or extra length ramps.

### **TITAN TRAILER SPECIFICATIONS**

DECK LENGTH = 10.5M

RIDE HEIGHT = .975M

OVERALL HEIGHT = 3.78M

OVERALL LENGTH = 14.73M

GROUND CLEARANCE = .37M

TOWING LENGTH = 13.88M

OVERALL WIDTH CLOSED = 2.48M

OVERALL WIDTH OPEN = 3.34M

RAMP WIDTH = .88M

SPREAD BETWEEN RAMP CENTRES (CLOSED) = 1.58M

SPREAD BETWEEN RAMP CENTRES (OPEN) = 2.5M

DISTANCE BETWEEN RAMPS CLOSED = .73M

DISTANCE BETWEEN RAMPS OPEN = 1.58M

RAMP APPROACH/DEPARTURE ANGLE = 17 DEG.

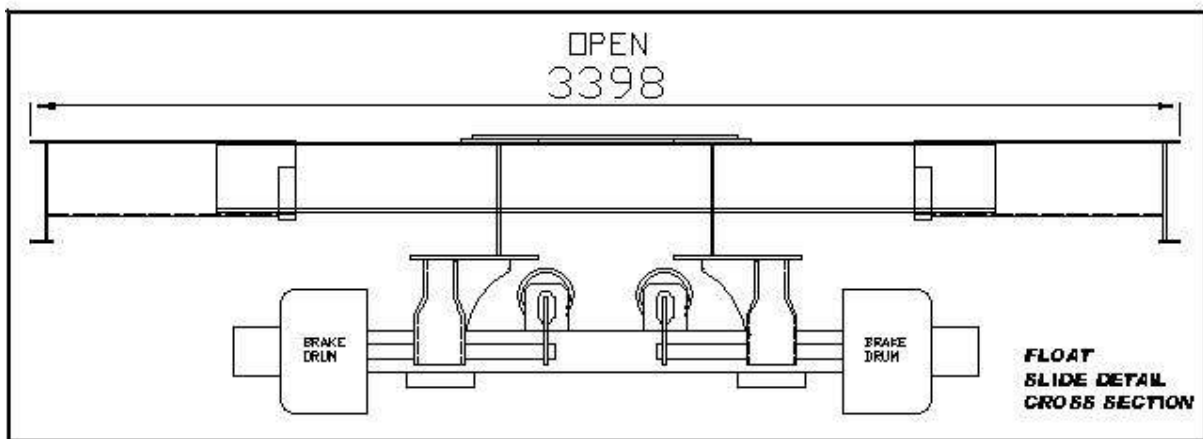
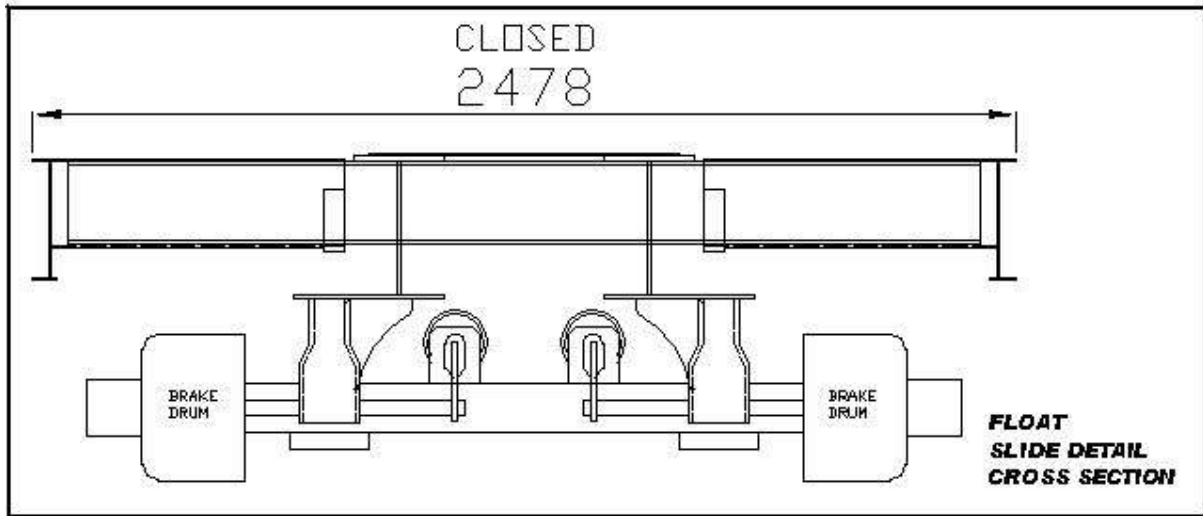

TITANIUM MANUFACTURING

GENERAL FLOAT SPECIFICATIONS

TARE = 114 L

